



# 1064 nm Polarization Maintaining Isolator (GK-PMI Series)

## ● Description

The 1064 nm Polarization Maintaining Isolator is a micro optics device with low insertion loss, high isolation, high return loss, high extinction ratio and excellent environmental stability and reliability. This fiber isolator is ideal for amplifiers, fiber lasers and test instrument applications.

## ● Key Features

- High Extinction Ratio
- Low Insertion Loss
- High Isolation

## ● Applications

Fiber Lasers

Amplifiers

Instrumentation

## ● Specifications

Parameter	Unit	Value			
		Single Stage		Dual Stage	
Stage	-	Single Stage		Dual Stage	
Grade	-	Grade P	Grade A	Grade P	Grade A
Center Wavelength ( $\lambda_c$ )	nm	1064			
Typ. Peak Isolation	dB	38	36	55	52
<sup>3</sup> Min. Isolation, $\lambda_c$ , 23 °C, $\leq$ 30 mW	dB	35	32	45	42
Typ. Insertion Loss, $\lambda_c$ , 23 °C	dB	1.5	1.6	2.4	2.6
Max. Insertion Loss, $\lambda_c$ , all temperature	dB	2.0	2.2	3.4	3.6
Min. Extinction Ratio	dB	20	18	20	18
Min. Return Loss (Input/Output)	dB	55/50	55/50	55/50	55/50
Max. Average Optical Power	mW	300			
Max. Peak Power for ns Pulse	kW	10			
Max. Tensile Load	N	5			
Fiber Type	-	PM 980 Panda Fiber			
Operating Temperature	°C	- 5 to + 50			
Storage Temperature	°C	- 40 to + 85			

<sup>1</sup>IL is 0.5 dB higher, RL is 5 dB lower, and ER is 2 dB lower for each connector added.

<sup>2</sup>Connector key is aligned to slow axis.

<sup>3</sup>The isolation is related to the input power. Please inform us when you need high isolation and operate above 30 mW.

## ● Package Dimensions

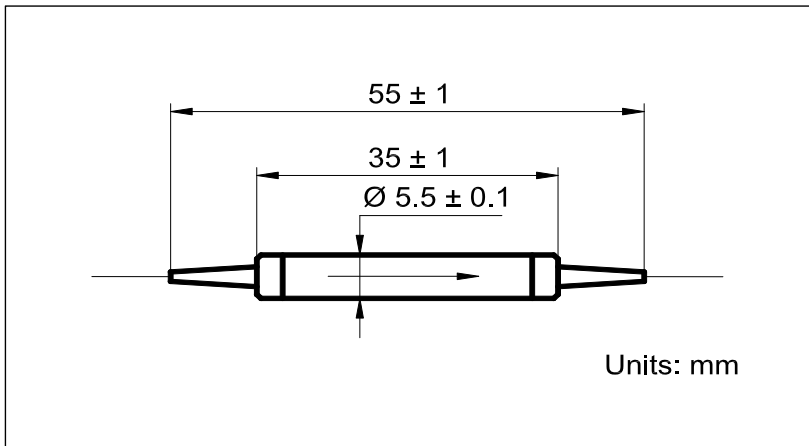

## ● Ordering Information

GK-PMI-06-①-②-③-④-⑤-⑥-⑦

### ①: Stage

1 - Single Stage  
2 - Dual Stage  
30 - 30 kW SS - Specify

### ②: Grade

P - Premium  
A - A Grade

### ③: Connector Type

1 - FC/UPC 4 - SC/APC  
2 - FC/APC N - None  
3 - SC/UPC S - Specify

### ④: Fiber Jacket

B - 250 μm Panda Fiber  
L - 900 μm Loose Tube  
S - Specify

### ⑤: Fiber Length

Q - 0.75 m  
S - Specify

### ⑥: Working Axis

F - Fast Axis Blocked  
B - Both Axis Working

### ⑦: Power Type

P - Pulse Application  
C - Continuous Wave