



## Polarization Beam Combiner/Splitter (GK-PBC/PBS Series)

### ● Description

The Polarization Beam Combiner/Splitter is a compact high performance light wave component that combines two orthogonal polarization signals into one output fiber. The most common application is to combine the light of two pump lasers into one single fiber to double the pump power in EDFA or Raman Amplifier. The device can also be used as a beam splitter.

### ● Specifications

Parameter	Unit	Single Stage
Operating Center Wavelength	nm	1064 1310
Operating Wavelength Range	nm	±50
Max. Insertion Loss	dB	0.6
Min. Extinction Ratio (for splitter only)	dB	20
Min. Return Loss	dB	50
Directivity	dB	50
Max. Optical Power (Continuous Wave)	mW	300
Fiber Type	-	PM Panda Fiber for Ports 1 & 2, SMF-28 or PM Panda Fiber for Port3
Max. Tensile Load	N	5
Operating Temperature	℃	- 5 to + 70
Storage Temperature	℃	- 40 to + 85

<sup>1</sup>IL is 0.3 dB higher, RL is 5 dB lower, and ER is 2 dB lower for each connector added.  
Connector key is aligned to slow axis.

## ● Package Dimensions

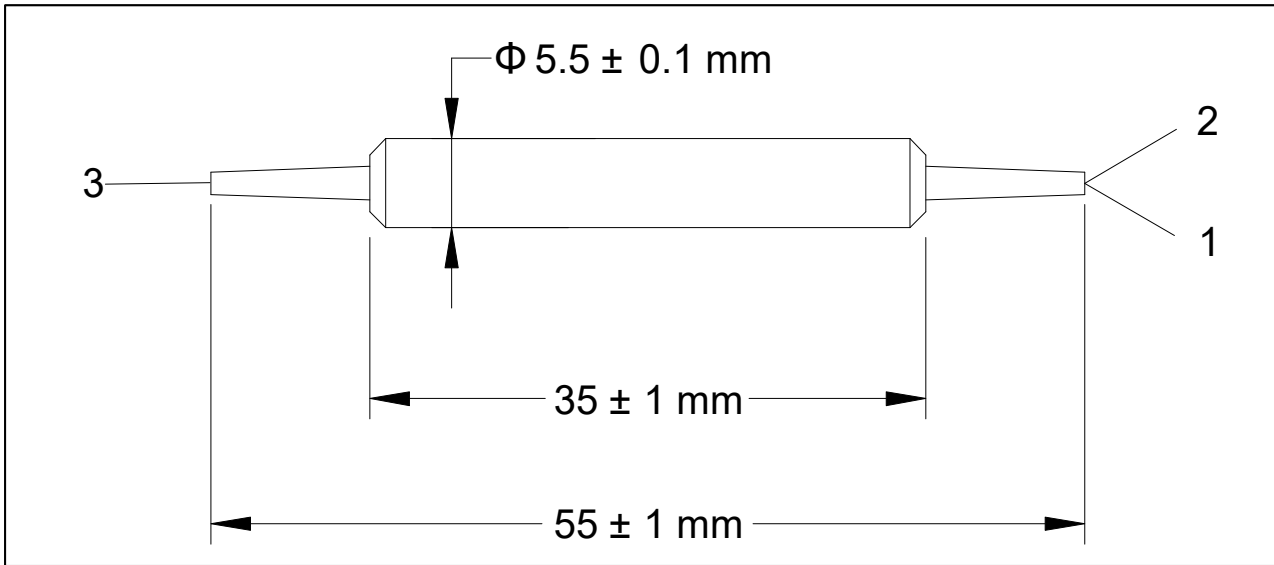

## ● Ordering Information

GK-PBC-①-②-③-④-⑤-⑥

GK-PBS-①-②-③-④-⑤-⑥

### ①: Wavelength

1064 - 1064 nm  
1310 - 1310 nm  
SS - Specify

### ②: Fiber Type for Port 3

1 - SMF-28  
2 - Slow axis aligned 45° to Port 1  
3 - Slow axis aligned to Port 1  
S - Specify

### ③: Connector Type

1 - FC/UPC 4 - SC/APC  
2 - FC/APC N - None  
3 - SC/UPC S - Specify

### ④: Fiber Jacket

B - 250  $\mu\text{m}$  Bare Fiber  
L - 900  $\mu\text{m}$  Loose Tube  
S - Specify

### ⑤: Fiber Length

Q - 0.75 m  
S - Specify

### ⑥: Grade

P - Premium