



Bandpass Filter (GK-BP Series)

● Description

The Bandpass Filter is a micro optics device based on environmentally stable thin-film filter technology. It is used to block out unwanted noise signals in EDFAs and fiber laser systems. The components are characterized with high isolation, low insertion loss, high return loss, excellent environmental stability and high power handling capability.

● Specifications

Parameter	Unit	Type A
Wavelength Range	nm	1528 - 1565
Max. Insertion Loss	dB	0.7
Typ. Insertion Loss	dB	0.5
Min. Isolation @ wavelength < 1521 nm and > 1574 nm	dB	12
Min. Return Loss	dB	50
Max. Polarization Dependent Loss	dB	0.1
Typ. Polarization Dependent Loss	dB	0.05
Thermal Stability	dB/°C	≤ 0.005
Thermal Wavelength Drift	nm/°C	≤ 0.003
Max. Optical Power (Continuous Wave)	mW	300
Max. Tensile Load	N	5
Fiber Type	-	SMF-28 Fiber
Operating Temperature	°C	-40to +105
Storage Temperature	°C	-40 to +85

¹IL is 0.3 dB higher, RL is 5 dB lower for each connector added.

● Package Dimensions

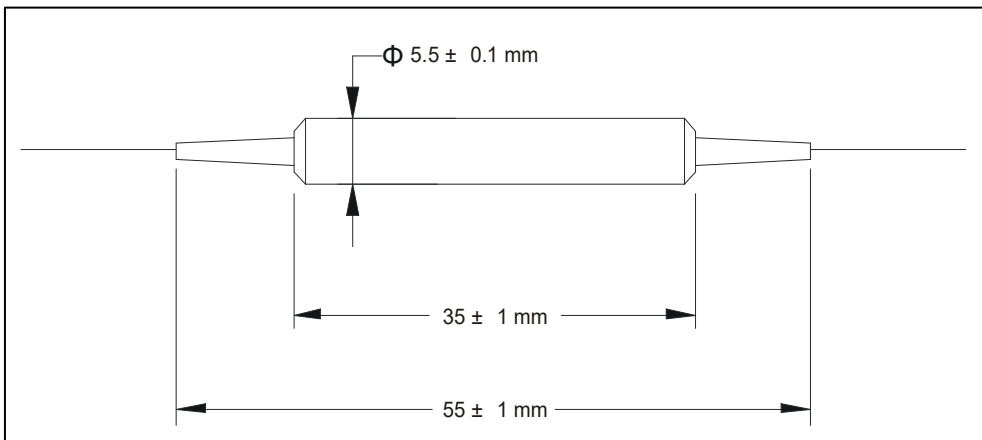

● Ordering Information

GK-BP-①-②-③-④

①: Wavelength

2865 - 1528 - 1565 nm

SSSS - Specify

④: Fiber Length

1 - 1.0 m

S - Specify

②: Connector Type

1 - FC/UPC

2 - FC/APC

3 - SC/UPC

4 - SC/APC

N - None

③: Fiber Type

B - 250 μ m Bare Fiber

L - 900 μ m Loose Tube

S - Specify