

High Power Polarization Insensitive Isolator (SLDHI Series)

Description

Rev 11

The 830 nm High Power Polarization Insensitive Isolator is characterized with low insertion loss, high isolation, high power handling, high return loss, excellent environmental stability and reliability. It is ideal for fiber laser and instrumentation applications.

Specifications

Parameter	Unit	Value
Center Wavelength (λ_c)	nm	830
Operating Wavelength Range	nm	$\lambda_c \pm 75$
Max. Polarization Dependent Loss	dB	0.2
Min. Isolation, λ_c , 23 °C, all polarization states	dB	28
Min. Isolation, $\lambda_c \pm 75$ nm, 23 °C, all polarization states	dB	23
Max. Insertion Loss, λ_c , 23 °C	dB	1.0
Max. Insertion Loss, $\lambda_c \pm 75$ nm, 23 °C	dB	3.0
Min. Return Loss (Input/Output)	dB	45/45
Max. Optical Power (Continuous Wave)	W	10
Max. Tensile Load	N	5
Fiber Type	-	HI 780 SM Fiber
Operating Temperature	°C	+ 10 to + 50
Storage Temperature	°C	0 to + 60

*IL is 0.5 dB higher, RL is 5 dB lower, and ER is 2 dB lower for each connector added.

Package Dimensions

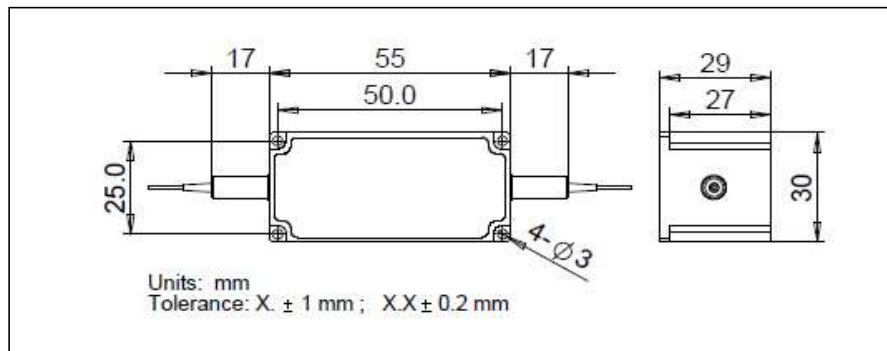

Ordering Information

HI-①①-②②-③-④-⑤

①①: Wavelength

83 - 830 nm

SS - Specify

②②: Handling Power

03 - 3 W

10 - 10 W

SS - Specify

③: Connector Type

1 - FC/UPC

2 - FC/APC

3 - SC/UPC

4 - SC/APC

N - None

S - Specify

④: Fiber Jacket

B - 250 μ m Bare Fiber

L - 900 μ m Loose Tube

S - Specify

⑤: Fiber Length

1 - 1.0 m

S - Specify