

## Features and Benefits

- **EM sensor technology**  
<1e<sup>-</sup> read noise
- **Fringe suppression technology as standard (970-BVF only)**  
Fringing minimized for NIR applications
- **Multi-Megahertz Readout**  
High repetition rates achievable with low noise electronics
- **TE cooling to -100°C**  
Negligible dark current without the inconvenience of LN<sub>2</sub>
- **UltraVac™**  
Critical for sustained vacuum integrity and to maintain unequalled cooling and QE performance, year after year
- **16 x 16 μm pixel size**  
Optimized pixel size for high resolution spectroscopy
- **Dual output amplifiers**  
Software-selectable between conventional High Sensitivity output (low light) or an Electron Multiplying output (ultra low light)
- **Crop Mode operation**  
Achieve the highest possible spectral rates of over 1,500 spectra per second
- **USB 2.0 connection**  
Ideal for laptop operation  
Seamless operation alongside USB-based Shamrock spectrograph family
- **Solis software for Spectroscopy**  
Comprehensive, user-friendly interface for simultaneous detector & spectrograph control
- **Software Development Kit (SDK)**  
Ease of control integration into complex setups: Matlab, Labview, Visual Basic or C/C++



## Market leading platform for ultra-sensitive and ultrafast spectroscopy.

EM technology enables charge from each pixel to be multiplied on the sensor before readout, providing single photon sensitivity. The Newton EM platform combines a 1600 x 200 (or 1600 x 400) array of 16 μm pixels, thermoelectric cooling down to -100°C for negligible dark current, 3MHz readout and USB 2.0 plug-and-play connectivity to provide unrivalled performance for spectroscopic applications. The dual output amplifiers allow software selection between either a conventional High Sensitivity or Electron Multiplying outputs to suit a broad range of photon regime conditions. This makes the Newton EMCCD the ideal choice for ultrafast chemical mapping applications e.g. SERS, TERS or luminescence mapping.

## Specifications Summary \*1

Active pixels	1600 x 200 or 1600 x 400
Pixel size (W x H)	16 x 16 μm
Image area	25.6 x 3.2 or 6.4 mm
Output node well depth:	
High Sensitivity mode	300,000 e <sup>-</sup>
Electron Multiplying mode	1,300,000 e <sup>-</sup>
Active area pixel well depth	200,000 e <sup>-</sup>
Maximum cooling	-100°C
Maximum spectra per sec	1,515
Read noise	As low as 2.8 e <sup>-</sup> (< 1 e <sup>-</sup> in EM mode)
Dark current	As low as 0.00007 e <sup>-</sup> /pixel/sec

## Key Specifications \*1

Model number	DU970P	DU971P
Sensor options	<ul style="list-style-type: none"> <li>• BVF: Back Illuminated CCD, Vis-optimized and anti-fringing</li> <li>• FI: Front Illuminated CCD</li> <li>• UV: Front Illuminated CCD with UV coating</li> <li>• UVB: Back Illuminated CCD with UV coating</li> </ul>	<ul style="list-style-type: none"> <li>• BV: Back Illuminated CCD, Vis-optimized</li> <li>• FI: Front Illuminated CCD</li> <li>• UV: Front Illuminated CCD with UV coating</li> <li>• UVB: Back Illuminated CCD with UV coating</li> </ul>
Active pixels *2	1600 x 200	1600 x 400
Pixel size	16 x 16 $\mu\text{m}$	
Image area	25.6 x 3.2 mm with 100% fill factor	25.6 x 6.4 mm with 100% fill factor
Minimum temperatures *3		
Air cooled	-80°C	
Coolant recirculator	-95°C	
Coolant chiller, coolant @ 10°C, 0.75l/min	-100°C	
Max spectra per second *4	649 (Full Vertical Bin), 1,515 (Crop Mode - 20 rows)	396 (Full Vertical Bin), 1,515 (Crop Mode - 20 rows)
System window type	BV, BVF, FI, UV, UVB sensors: UV-grade fused silica, 'Broadband VUV-NIR', unwedged (Various AR coatings & MgF <sub>2</sub> options available)	
Blemish specifications	Grade 1 as per sensor manufacturer definition	

## Advanced Specifications \*1

Dark current, e <sup>-</sup> /pixel/sec @ max cooling						
FI, UV	0.00007					
BV, UVB	0.00020					
BVF	0.00010					
Output node well depth						
High Sensitivity mode	300,000 e <sup>-</sup>					
Electron Multiplying mode	1,300,000 e <sup>-</sup>					
Register well depth						
High Sensitivity mode	400,000 e <sup>-</sup>					
Electron Multiplying mode	800,000 e <sup>-</sup>					
Active area pixel well depth	200,000 e <sup>-</sup> *5					
Read noise (e <sup>-</sup> ) *6	50 kHz	1 MHz	3 MHz	50 kHz	1 MHz	3 MHz
High Sensitivity mode: Typ (Max) - EM off	2.8 (5)	6.7 (9)	8.5 (12)	2.8 (5)	6.7 (9)	8.5 (12)
Electron Multiplying mode: Typ (Max) - EM off	8 (15)	25 (35)	38 (50)	8 (15)	25 (35)	38 (50)
Electron Multiplying mode: Typ (Max) - EM on	< 1	< 1	< 1	< 1	< 1	< 1
Sensitivity (e <sup>-</sup> /count)						
High Sensitivity mode	Adjustable from 0.8 - 3					
Electron Multiplying mode	Adjustable from 5 - 20					
Electron Multiplier gain	1 - 1,000 times (software controlled)					
Linearity *6	Better than 99%					
Digitization	16 bit					
Vertical clock speed *8	4.9, 9.8, 19, 38, 57 (software selectable)					

Have you found what you are looking for?

**Need to work further into the NIR?** The iDus InGaAs series, with up to 1024 pixel linear array with transmission to 2.2  $\mu\text{m}$ .

**Need a customized version?** Please contact us to discuss our Customer Special Request options.

The Newton series combines seamlessly with Andor's research grade Shamrock Czerny-Turner spectrographs.

## Dark Current <sup>\*9</sup>

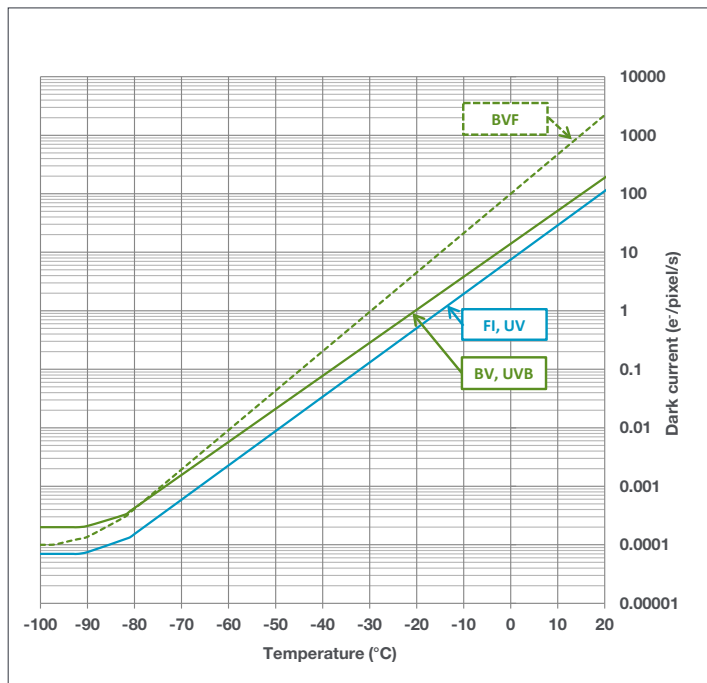

## Quantum Efficiency Curves <sup>\*10</sup>

25°C

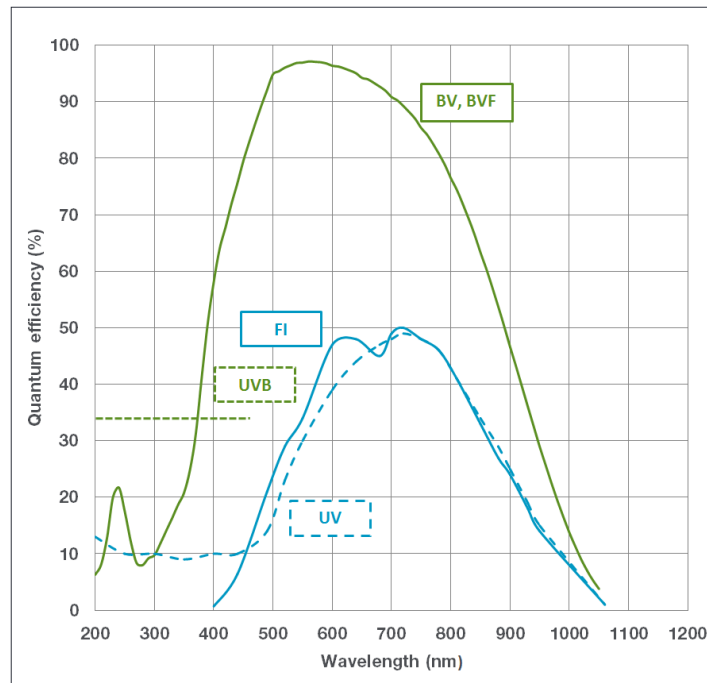

## Typical Setup

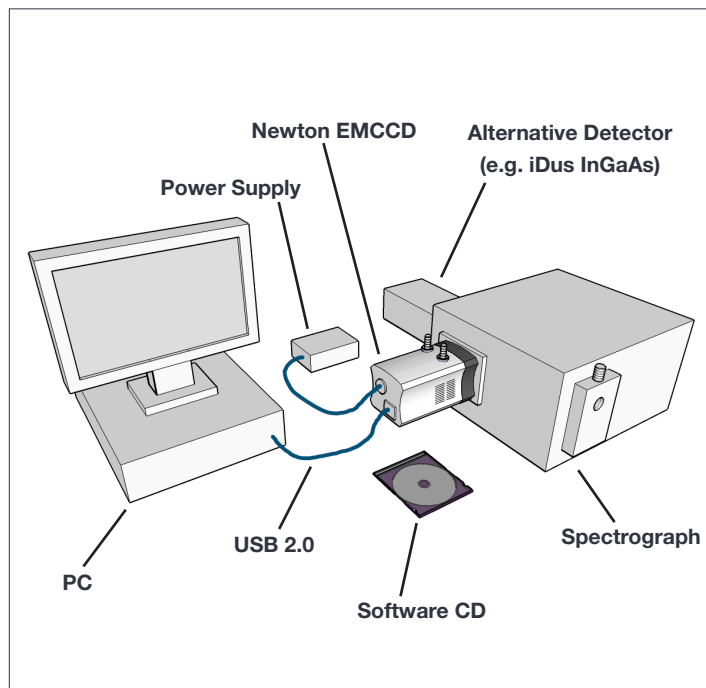

## Readout Rate & Speed <sup>\*11</sup>

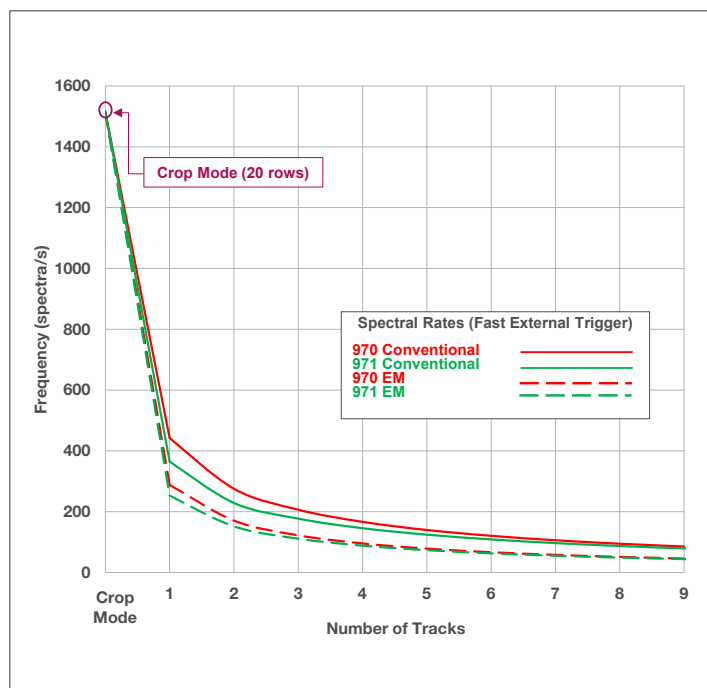

## Creating The Optimum Product for You

How to customize the Newton EMCCD series:

### Step 1.

Simply select from the 2 sensor array types that best suit your needs from the selection opposite.

### Step 2.

The Newton EMCCD comes with 5 options for sensor types. Please select the sensor which best suits your needs.

### Step 3.

Please indicate alternative window option if required.

### Step 4.

Please select which software you require.

### Step 5.

For compatibility, please indicate which accessories are required.

DU 970 P- BVF  
example shown

### Step 1.

#### Choose sensor array

**970P:** 1600 x 200 pixel array  
**971P:** 1600 x 400 pixel array

### Step 2.

#### Choose sensor type

**BV:** Back Illuminated CCD, Vis-optimized  
**BVF:** Back Illuminated CCD, Vis-optimized and anti-fringing (970 model only)  
**FI:** Front Illuminated CCD  
**UV:** Front Illuminated CCD with UV coating  
**UVB:** Back Illuminated CCD with UV coating

### Step 3.

#### Select alternative camera window (optional)

The standard window has been selected to satisfy most applications. However, other options are available. The alternative camera window code must be specified at time of ordering.

To view and select other window options please refer to the '**Camera Windows Supplementary Specification Sheet**' which gives the transmission characteristics, product codes and procedure for entering the order. Further detailed information on the windows can be found in the Technical note – '**Camera Windows: Optimizing for Different Spectral Regions**'.

### Step 4.

#### The Newton EMCCD also requires at least one of the following software options:

**Solis for Spectroscopy** A 32-bit and fully 64-bit enabled application for Windows (XP, Vista, 7 and 8) offering rich functionality for data acquisition and processing. AndorBasic provides macro language control of data acquisition, processing, display and export. Control of Andor Shamrock spectrographs and a very wide range of 3<sup>rd</sup> party spectrographs is also available, see list below.

**Andor SDK** A software development kit that allows you to control the Andor range of cameras from your own application. Available as 32 and 64-bit libraries for Windows (XP, Vista, 7 and 8) and Linux. Compatible with C/C++, C#, Delphi, VB6, VB.NET, LabVIEW and Matlab.

### Step 5.

#### The following accessories are available:

**XW-RECR** Coolant re-circulator for enhanced cooling performance  
**ACC-XW-CHIL-160** Oasis 160 Ultra Compact Chiller Unit (tubing to be ordered separately)  
**ACC-6MM-TUBING-2xxxxM** 6 mm tubing option for ACC-XW-CHIL-160  
**LM-C** C-mount lens adaptor  
**LM-NIKON-F** F-mount lens adaptor  
**LMS-NIKON-F-NS25B** Nikon F-mount lens adaptor with shutter  
**ACC-SD-VDM1000** Shutter Driver for NS25B Bistable Shutter (not needed for Shamrock spectrographs)  
**ACC-SHT-NS25B** Bistable Shutter, Standalone (not needed for Shamrock spectrographs)

#### Spectrograph Compatibility

The Newton series is fully compatible with Andor's Shamrock spectrograph (163 - 750 nm focal lengths) family. Spectrograph mounting flanges and software control are available for a wide variety of 3<sup>rd</sup> party spectrographs including, McPherson, JY/Horiba, PI/Acton, Chromex/Bruker, Oriol/Newport, Photon Design, Dongwoo, Bentham, Solar TII and others.



Newton EMCCD mounted on a Shamrock 750 mm triple grating imaging spectrograph, ideal for high resolution spectroscopy.

## Product Drawings

Dimensions in mm [inches]

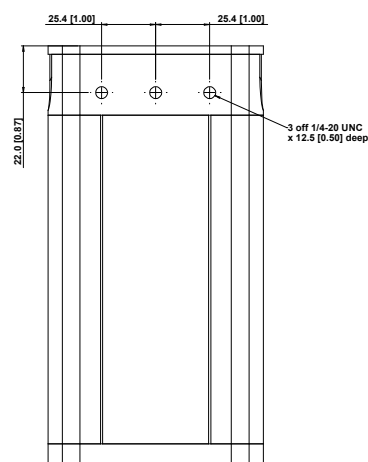
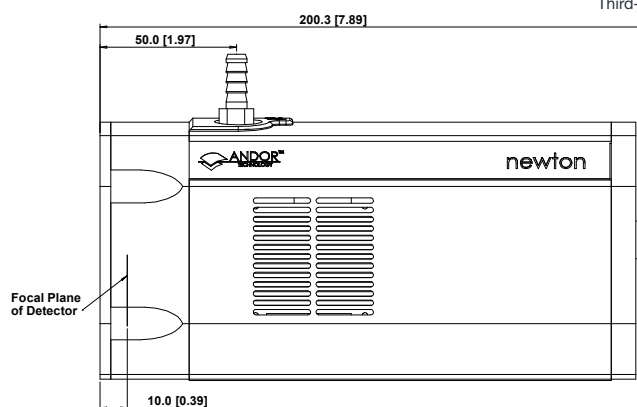
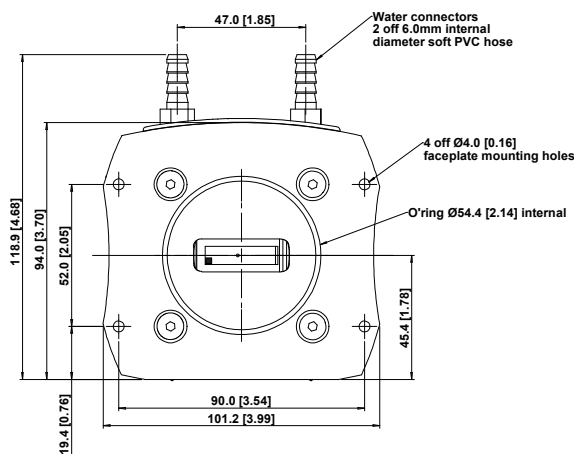
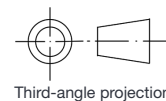

Mounting hole locations

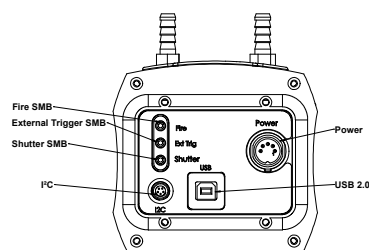

Rear connector panel

■ = position of pixel 1,1

Weight: 2.7 kg [5 lb 15 oz]

## Connecting to the Newton

### Camera Control

Connector type: USB 2.0

### TTL / Logic

Connector type: SMB, provided with SMB - BNC cable

1 = Fire (Output), 2 = External Trigger (Input), 3 = Shutter (Output)

### I<sup>2</sup>C connector

Compatible with Fischer SC102A054-130

1 = Shutter (TTL), 2 = I<sup>2</sup>C Clock, 3 = I<sup>2</sup>C Data, 4 = +5 Vdc, 5 = Ground

### Minimum cable clearance required at rear of camera

90 mm

## Applications & Techniques Guide

	BV models	BVF models	FI models	UV models	UVB models
Absorption/Transmittance/Reflection	✓	✓		✓	✓
Atomic Emission Spectroscopy	✓	✓	✓	✓	
Fluorescence & Luminescence	✓	✓	✓	✓	✓
Raman Spectroscopy (244 – 488 nm)	✓	✓		✓	✓
Raman Spectroscopy (514, 532 nm)	✓	✓		✓	
Raman Spectroscopy (633 nm)	✓	✓	✓		
Photon Counting	✓	✓			✓
Single Molecule Spectroscopy	✓	✓		✓	✓

✓ = Suitable

✓ = Optimum



## Order Today

Need more information? At Andor we are committed to finding the correct solution for you. With a dedicated team of technical advisors, we are able to offer you one-to-one guidance and technical support on all Andor products. For a full listing of our local sales offices, please see: [andor.com/contact](http://andor.com/contact)

Our regional headquarters are:

### Europe

Belfast, Northern Ireland  
Phone +44 (28) 9023 7126  
Fax +44 (28) 9031 0792

### Japan

Tokyo  
Phone +81 (3) 3518 6488  
Fax +81 (3) 3518 6489

### North America

Connecticut, USA  
Phone +1 (860) 290 9211  
Fax +1 (860) 290 9566

### China

Beijing  
Phone +86 (10) 5129 4977  
Fax +86 (10) 6445 5401

### Items shipped with your camera:

- 1x 2m BNC - SMB connection cable
- 1x 3m USB 2.0 cable Type A to Type B
- 1x Set of Allen keys (7/64", 3/32" & 3 mm)
- 1x Power supply with mains cable
- 1x Quick launch guide
- 1x CD containing Andor user guides
- 1x Individual system performance booklet
- 1x CD containing either Solis software or SDK (if ordered)

### Footnotes: Specifications are subject to change without notice

1. Figures are typical unless otherwise stated.
2. Edge pixels may exhibit a partial response.
3. Cooling is provided by the use of an external mains driven power supply. Minimum temperatures listed are typical values with ambient temperature of 20°C. Systems are specified in terms of minimum dark current achievable rather than absolute temperature.
4. Based on horizontal pixel readout rate of 3 MHz and a vertical shift speed (in conventional mode) of 4.9  $\mu$ s. Achievable spectral rates will vary with selected trigger mode.
5. Shown for EM mode. For Conventional mode the measurable well depth value will be lower, as a result of the combination of higher sensitivity values and A/D 16 bits digitization.
6. Readout noise is for the entire system. It is a combination of CCD readout noise and A/D noise. Measurement is for Single Pixel readout with the CCD at a temperature of -80°C and minimum exposure time under dark conditions. Noise values will change with readout mode.
7. Linearity is measured from a plot of counts vs exposure time under constant photon flux up to the saturation point of the system.
8. Vertical speeds are software selectable. All sensors are designed to give optimum Charge Transfer Efficiency (CTE) at 9.7  $\mu$ s vertical pixel shift, some decrease in CTE may be observed at faster shift speeds.
9. The graph shows typical dark current level as a function of temperature. The dark current measurement is averaged over the CCD area excluding any regions of blemishes.
10. Quantum efficiency of the sensor as supplied by the sensor manufacturer.
11. The chart shows the maximum possible readout rates available when using Multi-track mode, each track being defined as 20 rows. Crop mode is a specific single-track readout method optimized for rapid kinetic-type acquisition.

### Minimum Computer Requirements:

- 3.0 GHz single core or 2.4 GHz multi core processor
- 2 GB RAM
- 100 MB free hard disc to install software (at least 1 GB recommended for data spooling)
- USB 2.0 High Speed Host Controller capable of sustained rate of 40 MB/s
- Windows (XP, Vista, 7 and 8) or Linux

### Operating & Storage Conditions

- Operating Temperature: 0°C to 30°C ambient
- Relative Humidity: <70% (non-condensing)
- Storage Temperature: -25°C to 50°C

### Power Requirements

- 110 - 240 VAC, 50 - 60 Hz



Windows is a registered trademark of Microsoft Corporation.  
Labview is a registered trademark of National Instruments.  
Matlab is a registered trademark of The MathWorks Inc.