

High Power Polarization Maintaining Tap Isolator (HPMTI Series)

Rev 11

Description

The High Power Polarization Maintaining Tap Isolator is characterized with low insertion loss, high isolation, high power handling, high return loss, excellent environmental stability and reliability. It is ideal for fiber laser and instrumentation applications.

Specifications

Parameter	Unit	Value
Center Wavelength (λ_c)	nm	1030, 1064
Operating Wavelength Range	nm	$\lambda_c \pm 10$
Tap Ratio (Tap IL = $-10 \cdot \log(\text{Tap Ratio}) + \text{E.L.}$)	%	$0.1 \pm 0.05, 1 \pm 0.5, 2 \pm 0.8, 5 \pm 1.0, 10 \pm 2.0$
Min. Extinction Ratio	dB	20
Min. Isolation, $\lambda_c, 23^\circ\text{C}$, all polarization states	dB	25
Typ. Excess Loss, 23°C	dB	0.8
Max. Excess Loss, 23°C	dB	1
Min. Return Loss (Input/Output)	dB	45/45
Max. Average Optical Power	W	10
Max. Peak Power for ns Pulse	kW	10
Max. Tensile Load	N	5
Fiber Type	-	specified by ordering info.
Operating Temperature		+ 10 to + 50
Storage Temperature		0 to + 60
'Output IL = $-10 \cdot \log(1 - \text{Tap Ratio}) + \text{E.L.}$		

Package Dimensions

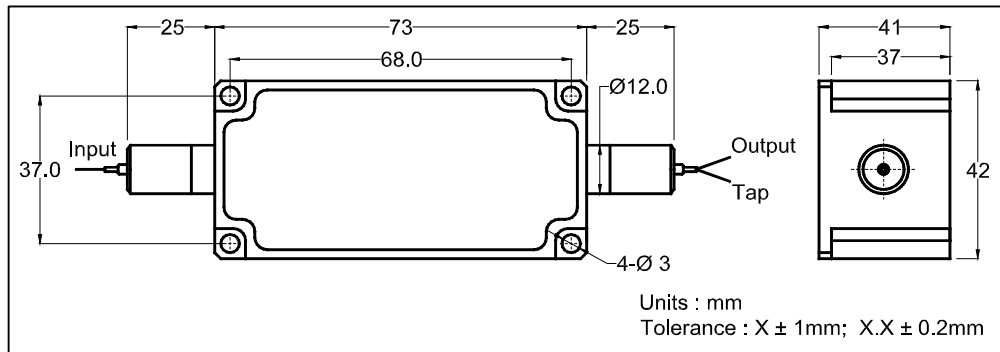

Ordering Information

HPMTI-①①-②②-③③-④④-⑤⑤-⑥⑥-⑦⑦-⑧⑧-⑨⑨-⑩⑩

①①: Wavelength 03 - 1030 nm 06 - 1064 nm SS - Specify	②②: Handling Power 05 - 5 W 10 - 10 W SS - Specify	③③: Tap Ratio 01 - 1/999 05 - 5/95 01 - 1/99 10 - 10/90 02 - 2/98 SS - Specify	④④: Connector Type N - None	⑤⑤: Fiber Jacket B - Bare Fiber L - 900 μm Loose Tube S - Specify
⑥⑥: Fiber Length Q - 0.75 m S - Specify	⑦⑦: Working Axis F - Fast Axis Blocked	⑧⑧: Fiber Type for I&O 1 - PM 980 Fiber 2 - Nufern FUD-3460 S - Specify	⑨⑨: Fiber Type for T 1 - HI 1060 Fiber 2 - PM 980 Fiber S - Specify	⑩⑩: Power Type P - Pulsed C - Continuous Wave