

# PDD-1600 pulsed diode driver

## User manual

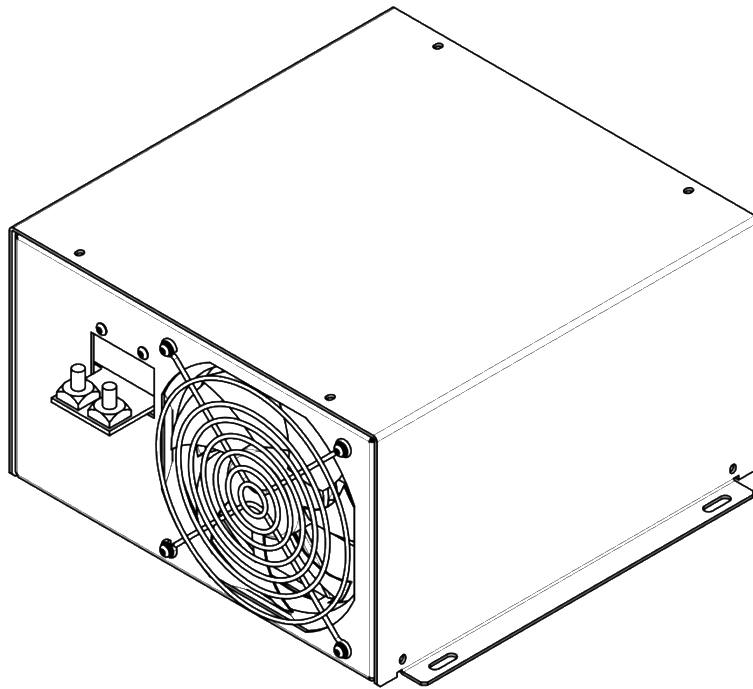

**Warning!** This equipment may be dangerous.  
Please read user manual before starting operations.

**Important note.** Please measure output with adequate load only (diodes). Resistive load connected to the output won't destroy the driver, but will severely distort its behavior.



## Warnings

---



**Warning!** The equipment is CLASS I ME EQUIPMENT.  
To avoid risk of electrical shock, the equipment must be protectively grounded.



**Warning!** There is no user-serviceable parts inside the device.  
Do not self-repair the driver. Do not even open the enclosure, because of electrical shock risk with residual high voltage.



**Warning!** Equipment is not suitable for use in presence of a flammable anesthetic mixture with air or with oxygen or nitrous oxide.

## Overview / Applications

---

PDD-1600 is a series of high-power pulsed diode drivers. Peak output power is up to 10kW (with user selectable  $I_{MAX}$  and  $V_{MAX}$ ), averaged output power is up to 1600W.

Driver was specially designed for direct diode hair removal application. Driver's input is 100-240VAC by default. Modifications with 200-240VAC input and increased output power (over 2000W) are available upon request.

## Cooling

---

The module contains a fan for active cooling. No additional cooling is required.

## Appearance / Layout

---



## Connections, signals, signal description

### INTERFACE: 15-pin D-SUB Female

PIN (color)	DESIGNATION	DESCRIPTION
1 (green)	ENABLE	+5V TTL applied to this pin enable PDD. While 0V are applied to this pin or pin is unconnected module is disabled. Once <i>Fault</i> has occurred module is blocked till you eliminate fault cause, then <i>disable</i> module and <i>enable</i> it again.
2 (orange)	FAULT	If module is <i>enabled</i> and some trouble has occurred, module automatically stops operations and sets <i>Fault</i> status ( <i>Fault</i> loop is “closed”). <b>Fault can be caused by following reasons:</b> - <b>overheating</b> - <b>mains voltage interruption</b> - <b>maximum pulse energy exceeded</b> To remove Fault state one should <i>disable</i> driver and <i>enable</i> it again In case of normal operations <i>Fault</i> loop is “opened”. Maximum allowed current in <i>Fault</i> loop is 50mA.
3 (transparent)	PULSE 1	+5V TTL pulse should be applied to pin 3 and to pin 8 simultaneously in order to obtain pulsed current from PDD-1600. In cases if 0V is applied to one of these pins or at least one of these pins is unconnected, there will be no current from PDD-1600.
4 (black)	PULSE 2 RETURN	Return of Pulse 2 signal
5 (yellow)	PULSE 1 RETURN	Return of Pulse 1 signal
6	N/C	
7 (blue)	CURRENT PROGRAM	Voltage applied to this pin sets output current. 0-10V DC are linear with 0- $I_{MAX}$ .
8 (white)	PULSE 2	+5V TTL pulse should be applied to pin 3 and to pin 8 simultaneously in order to obtain pulsed current from PDD-1600. In cases if 0V is applied to one of these pins or at least one of these pins is unconnected, there will be no current from PDD-1600.
9 (purple)	ENABLE RETURN	Return of Enable signal
10, 11, 12, 13	N/C	

<b>14 (red)</b>	<b>+15V DC AUXILIARY OUTPUT</b>	Auxiliary +15V DC output. Maximum output current 50mA.
<b>15 (white/blue)</b>	<b>INTERFACE RETURN</b>	Return of other Interface signals (namely Fault, Current program and +15V DC)

### **AC POWER INPUT:** Screw terminal

---



100-240 VAC

### **OUTPUT POSITIVE AND OUTPUT NEGATIVE:** M6 studs

---

<b>PIN (color)</b>	<b>DESCRIPTION</b>
<b>DIODE “+” (red)</b>	To laser diode anode
<b>DIODE “-” (black)</b>	To laser diode cathode

### **LEDs:**

---

LED1 (red) – lights, if driver sets a Fault state

LED2 (red) – lights when high voltage presents at inner buffer capacitor bank

### **GROUND:** M5 stud

---

Module should be grounded using this stud.

Grounding should be done before powering the system.

#### **Grounding policy**

By default OUTPUT POSITIVE and OUTPUT NEGATIVE are isolated from the chassis’ ground (i.e. output is floating).

Modifications with grounded anode or grounded cathode are available upon request.

### **Operations notes**

---

1. The proper sequence of driver's start up procedure is 'power -> enable -> pulse'. Other sequences are considered as incorrect
2. Fault state is set when fault condition is met AND driver is enabled
3. To remove fault state one should disable driver and enable it again

## Specifications

---

### ELECTRICAL

---

<b>INPUTS</b>	
Input voltage	100-240VAC 50/60Hz (*)
Input current	<20A
<b>OUTPUT</b>	
Maximum output voltage ( $V_{MAX}$ )*	50V by default (up to 100V on request)
Maximum output current ( $I_{MAX}$ )*	200A by default (other on request)
Peak power ( $P_{PEAK}$ )*	Up to 10kW (other on request)
Pulse width (t)*	1ms - 100ms (other on request)
Maximum pulse energy ( $E_{MAX}$ )*	500J
Risetime/falltime	<1ms (10-90% level)
Averaged power ( $P_{AV}$ )*	>1600W (*)
Pulse repetition rate (f)*	>10Hz
*) Not at the same time. There are some limitations:	
1. $V_{MAX} * I_{MAX} < P_{PEAK}$	
2. $V_{MAX} * I_{MAX} * t < E_{MAX}$	
3. $V_{MAX} * I_{MAX} * t * f < P_{AV}$	
Current accuracy	<1% of $I_{MAX}$
Current overshoot	<1% of $I_{MAX}$
<b>REGULATIONS</b>	Safety as per IEC 60601-1 EMC as per IEC 60601-1-2 RoHS compliant
<b>COOLING</b>	No external cooling is required
<b>ENVIRONMENT</b>	
Operation temperature	10 ... +40 °C
Storage temperature	-20 ... +60 °C
Humidity	90%, non-condensing

(\*) Modifications with narrowed input voltage range and increased output power (>2000W) are available upon request.

### MECHANICAL

---

Dimensions	See dimensional drawing below
Weight	Approx. 5kg

# Dimensions (standard, supplied by default)

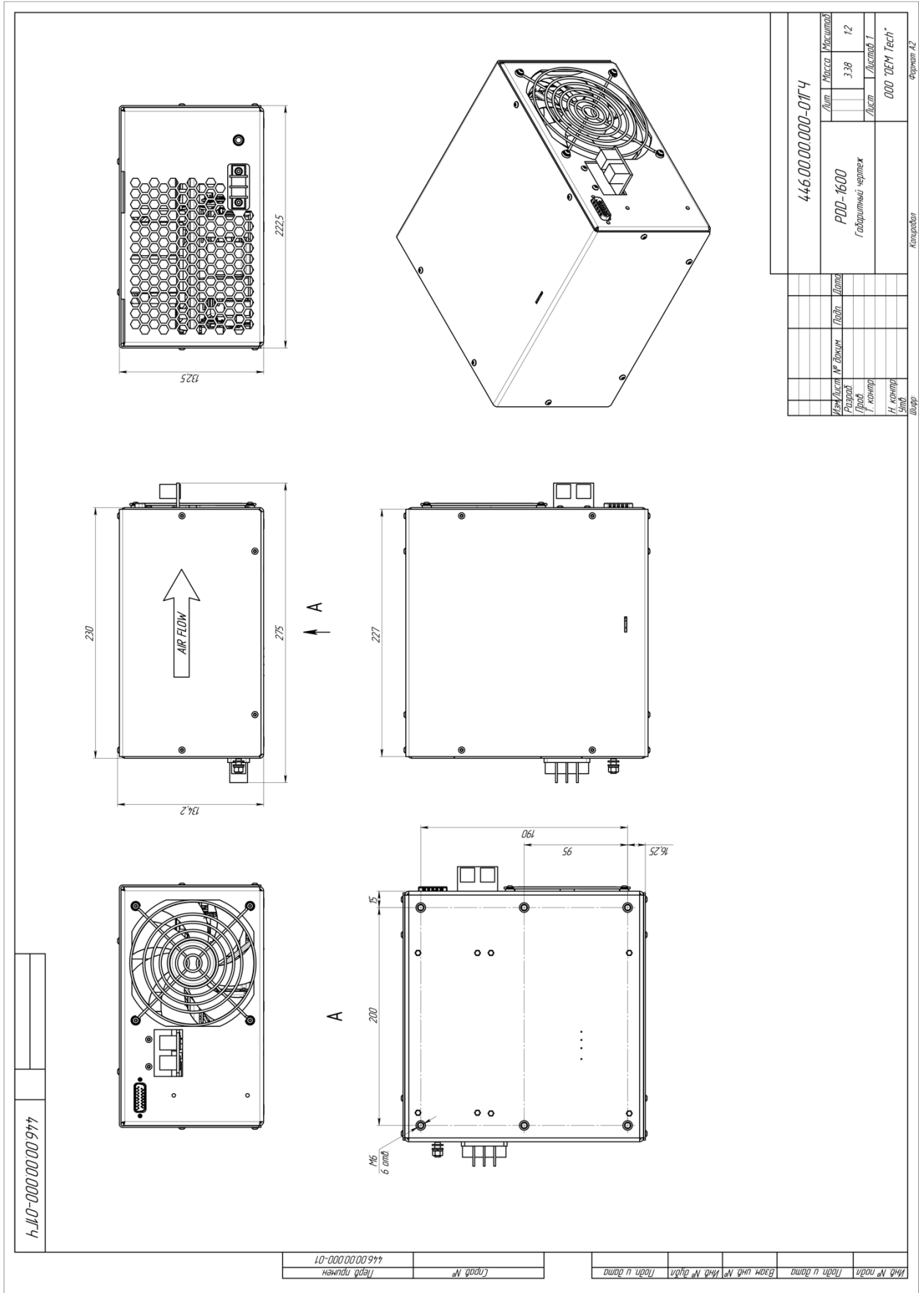

# Dimensions (reversed fan, available upon request)

