



Polarization Beam Combiner/Splitter (GK-IPBC/IPBS Series)

● Description

The Isolator Polarization Beam Combiner/Splitter is a compact device which provides both polarization beam combining and optical isolation in one integrated component. The most common application is to combine the light of two pump lasers into one single fiber to double the pump power in EDFA or Raman Amplifier. IPBC/IPBS has extremely low insertion loss, and it can improve the amplifier performance.

● Specifications

Parameter	Unit	Single Stage Dual stage
Center Wavelength (λ_c)	nm	1310, 1480, 1550
Operating Wavelength Range	nm	$\lambda_c \pm 20$
Typ. Insertion loss	dB	0.45 0.55
Max. Insertion loss	dB	0.7 0.8
Min. Isolation	dB	20 42
Min. Extinction Ratio (for splitter only)	dB	20 20
Min. Return Loss	dB	50
Directivity	dB	50
Max. Optical Power (continuous wave)	mW	300
Fiber Type	-	PM Panda Fiber for Ports 1 & 2, SMF-28 or PM Panda Fiber for Port 3
Max. Tensile Load	N	5
Operating Temperature	°C	- 5 to + 70
Storage Temperature	°C	- 40 to + 85

¹IL is 0.3 dB higher, RL is 5 dB lower, and ER is 2 dB lower for each connector added.
Connector key is aligned to slow axis.

● Package Dimensions

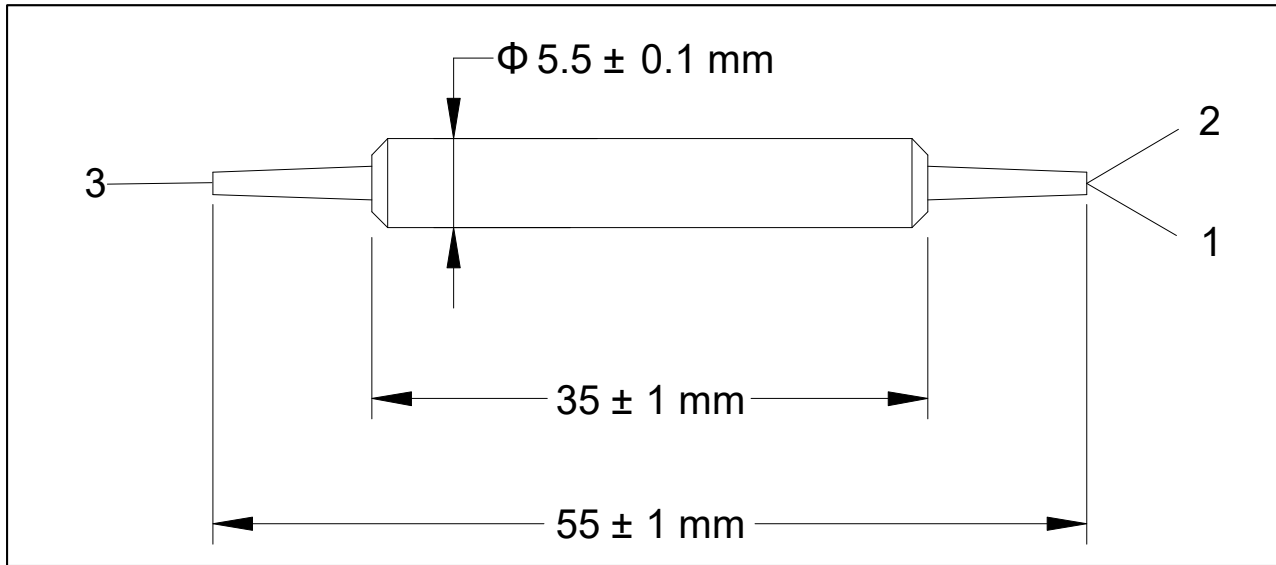

● Ordering Information

GK-IPBC-①-②-③-④-⑤-⑥

GK-IPBS-①-②-③-④-⑤-⑥

①: Wavelength

31 - 1310 nm

48 - 1480 nm

55 - 1550 nm

SS - Specify

②: Fiber Type for Port 3

1 - SMF-28

2 - Slow axis aligned 45° to Port 1

3 - Slow axis aligned to Port 1

S - Specify

③: Connector Type

1 - FC/UPC 4 - SC/APC

2 - FC/APC N - None

3 - SC/UPC S - Specify

④: Fiber Jacket

B - 250 μm Bare FiberL - 900 μm Loose Tube

S - Specify

⑤: Fiber Length

Q - 0.75 m

S - Specify

⑥: Stage

1 - Single stage

2 - Dual Stage