



Polarization Maintaining Tap Coupler (GK-PMTC Series)

● Description

The Polarization Maintaining Tap Coupler is manufactured by using advanced technology to allow the input signal to be splitted at various ratios with high extinction ratio.

● Specifications

Parameter	Unit	Value
Center Wavelength	nm	1310, 1550
Operating Wavelength Range	nm	$\lambda_c \pm 40$
Configuration	-	1 × 2 2 × 2
Max. Excess Loss	dB	0.7 1.0
Max. Uniformity (only for 50%)	dB	0.6 0.8
Tap Ratio	%	1 ± 0.2, 2 ± 0.4, 4 ± 0.8, 5 ± 1.0, 10, 20 and 50
Min. Return Loss	dB	50 50
Min. Extinction Ratio	dB	20 20
Max. Optical Power (Continuous Wave)	mW	300
Max. Tensile Load	N	5
Operating Temperature	°C	-5 to +70
Storage Temperature	°C	-40 to +85
Fiber Type	-	SMF-28 or PM Panda Fiber for tap port PM Panda Fiber for Input & Output ports

¹IL is 0.3 dB higher, RL is 5 dB lower, and ER is 2 dB lower for each connector added.
Connector key is aligned to slow axis.

● Package Dimensions

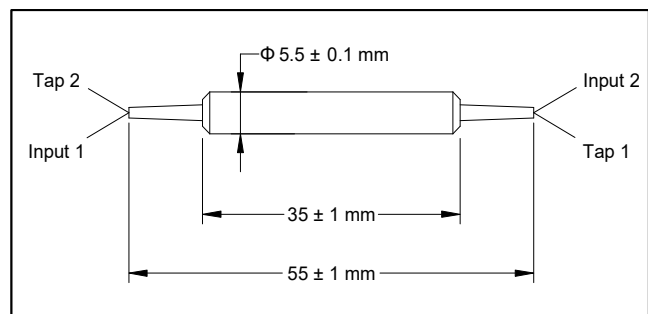
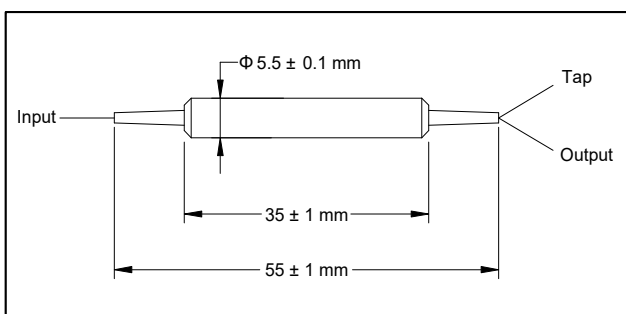

● Ordering Information

GK-PMTC-①-②-③-④-⑤-⑥-⑦-⑧

①: Configuration

1 - 1 × 2
2 - 2 × 2

②: Wavelength

31 - 1310 nm
55 - 1550 nm
SS - Specify

③: Coupling Ratio

01 - 01/99 10 - 10/90
02 - 02/98 20 - 20/80
04 - 04/96 50 - 50/50
05 - 05/95 SS - Specify

④: Connector Type

1 - FC/UPC
2 - FC/APC
3 - SC/UPC
4 - SC/APC
N - None
S - Specify

⑤: Fiber Jacket

B - 250 μm Bare Fiber
L - 900 μm Loose
S - Specify

⑥: Fiber Type for Tap Port

M - SMF-28 Fiber
P - Panda Fiber
S - Specify

⑦: Fiber Length

Q - 0.75 m
S - Specify

⑧: Working Axis

F - Fast Axis Blocked