

PRECESSION ELEPHANT III

SCAN HEAD FOR HIGH-PRECISION DRILLING AND CUTTING

Novanta develops photonics solutions through our globally recognized brands—ARGES, Cambridge Technology, Laser Quantum and Synrad—specializing in cutting-edge components and sub-systems for laser-based diagnostic, analytical, micromachining and fine material processing applications. Powerful lasers, coupled with advanced beam steering and intelligent sub-systems incorporating software and controls, deliver extreme precision and performance, tailored to our customers' demanding applications.

PRECESSION SCANNING

The next generation Precession Elephant is designed for highprecision laser drilling, cutting and micromachining applications. Built for durability and performance, the Precession Elephant series are used in 24/7 production facilities around the world.

The Precession Elephant III or PE III scan head offers maximum flexibility for the drilling and cutting of complex geometries of various taper angles and shapes, and allow the production of perfectly round, elliptical, square or custom-shaped micro-holes. This next generation scan head is available for green infrared wavelength ranges.

PE III can be used with all major ultra-short pulsed laser sources available on the market today. In addition, the new PE III makes it possible to monitor the laser process and the laser beam properties during production. This new scan head offers improved power handling capabilities, ease of setup and alignment, as well as additional functionalities for a 24/7 production. The unit comes pre-adjusted to simplify the sub-system setup and calibration of the polarization, and minimize downtimes for the end-user.



TAILORED ENGINEERING CAPABILITIES

Through our highly specialized expertise and resources we can provide tailored solutions for your application needs. With a large selection of different laser sources, scan heads and handling systems to choose from, we can develop laser processes that are perfectly tailored to a wide variety of customer-specific products, components and materials.

- Sub-systems that include laser and beam path
- Customer-specific software extensions
- Laser process development
- Sample production

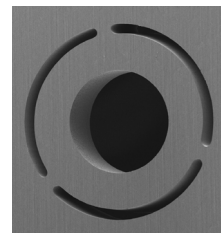

Micromachining

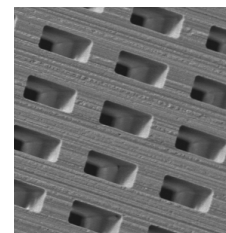

Micro-drilling

PRECESSION ELEPHANT III

Specifications	PE III
Number of Axes	5 axes
	X Y Z coordinates
	Two beam inclination angles
Wavelength	515 - 540 nm (VIS)
	1020 – 1080 nm (NIR)
Focal Length of Objective Lens	60 mm
Precession Frequency	300-650 Hz (18000-39000 rpm)
Maximum Pulse Energy / Shortest Pulse Length	VIS: 250 μ J @ 250 fs IR: 500 μ J @ 250 fs
Cooling	Water
Purge Gas (Head / Lens)	Nitrogen / Any
Polarization (Input / Output)	Linear / Circular
Cameras - Alignment (2)	Industrial cameras with e2v 1.3 megapixel CMOS sensor
Camera - Visual	Progressive scan 4.92 megapixel, 4:3 aspect ratio

PROCESS CONTROL OPTIONS

PE III

- Through-the-lens vision module with built-in illumination
- Polarization control for best-in-class processing results
- Two alignment cameras for beam adjustment
- Automatic beam position calibration
- Available as scan head
- Available as scan head with matched laser and beam path
- Stationary or moveable mounting

PRECSSION ELEPHANT III

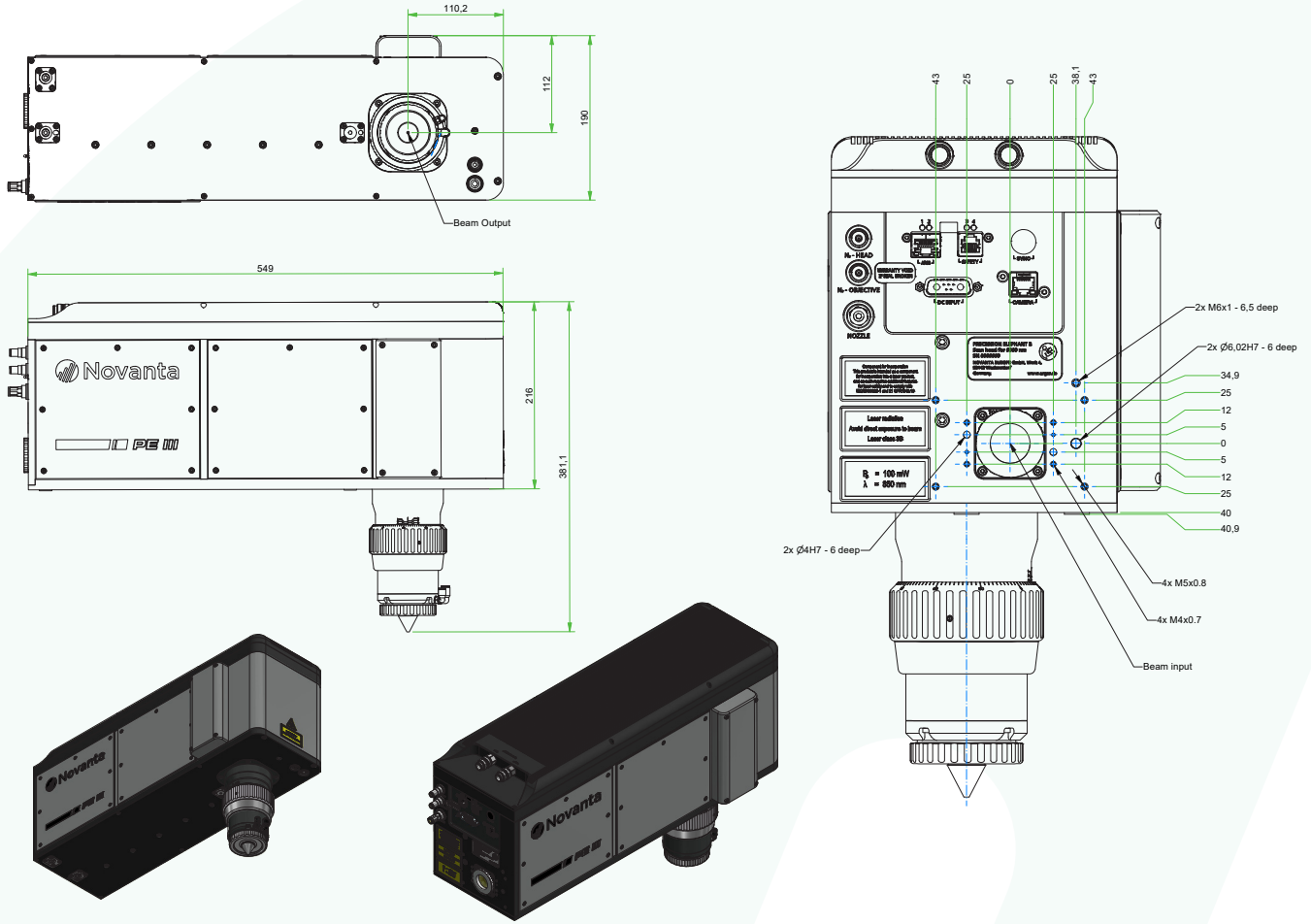

Notes:
All angles are in optical degrees, unless otherwise noted. Dimensions are in millimeters. All specifications are subject to change without notice.

CONTACT US

Americas, Asia Pacific
Novanta Headquarters
Bedford, USA
P +1-781-266-5700
Photonics@Novanta.com

Europe, Middle East, Africa
Novanta Europe GmbH
Wackersdorf, Germany
P +49 9431 7984-0
Milan, Italy
P +39-039-793-710
Photonics@Novanta.com

China
Novanta Sales & Service Office
Shenzhen, China
P +86-755-8280-5395
Suzhou, China
P +86-512-6283-7080
Photonics.China@Novanta.com

Japan
Novanta Service & Sales Office
Tokyo, Japan
P +81-3-5753-2460
Photonics.Japan@Novanta.com