

Shenzhen SanQianJia Technology Co., Ltd.

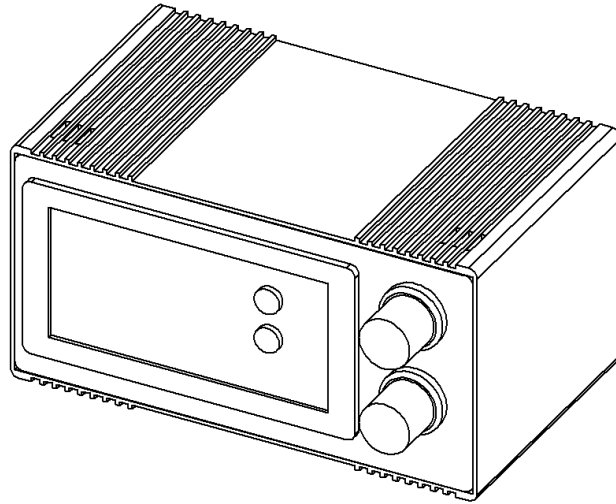

UV LED Spot Curing System UV1S

sales@uv-disinfect.com

Shenzhen SanQianJia Technology Co., Ltd.

Handheld Point Light :

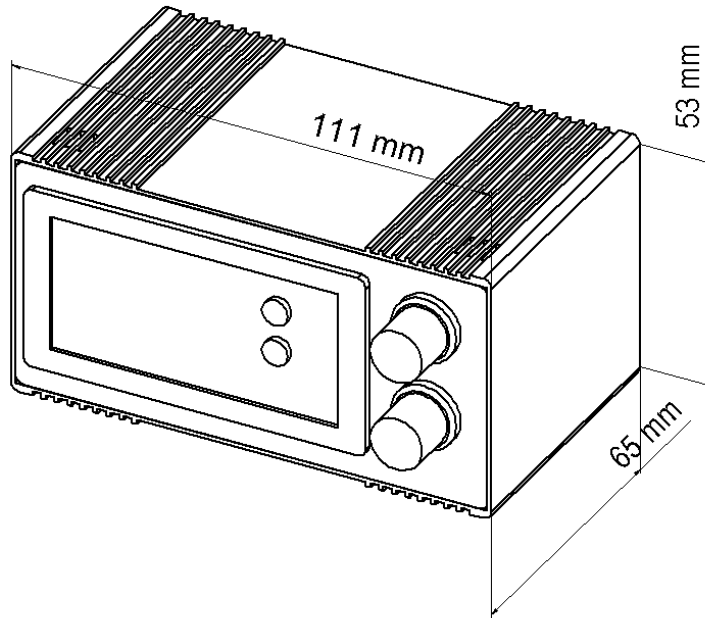

Specifications :

1.	Light source	UV LED
2.	Wavelength	365±5nm
3.	Optical power	1000mw/cm ²
4.	Spot area	φ10mm @ 20mm
5.	Power percentage	0-100%
6.	Time setting	1s-999s
7.	Switch control mode	controller switch, Foot switch
8.	Maximum power consumption	5W
9.	Controller power input	DC 12V 2A

Shenzhen SanQianJia Technology Co., Ltd.

10.	Power adapter input	AC110-220V
-----	---------------------	------------

Instructions for use :

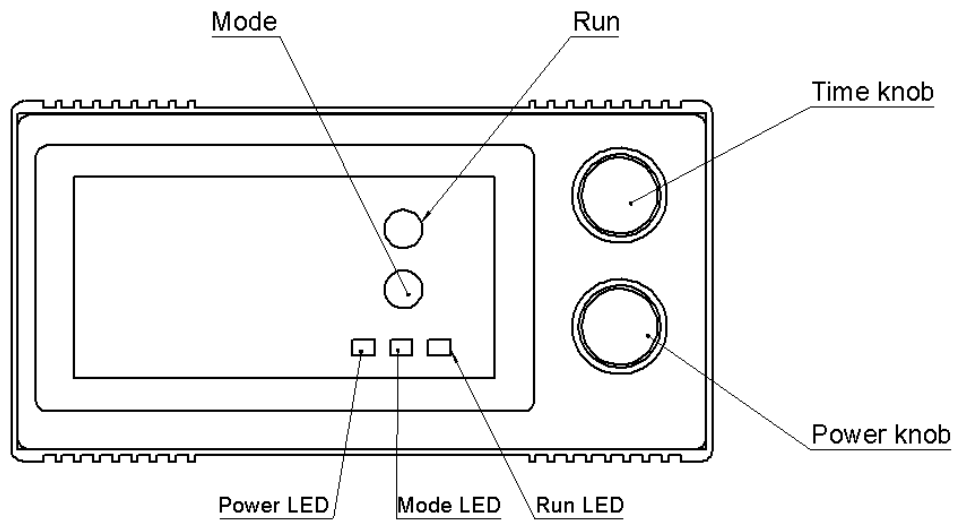

Run: Click the Run button to start the UV LED irradiation head, and the Run LED indicator lights up. Click the Close button again, and the Run LED indicator turns off.

Mode: Click the Mode button to enter the countdown mode, the Mode LED indicator lights up, and the task will be executed according to the set countdown. Click the Run button or use the foot switch to turn on the UV LED irradiation head. Wait for the countdown to end and the UV LED irradiation head will turn off, and the Mode LED indicator will go out. You can interrupt the shutdown the irradiation head by clicking the Run button or the foot switch again..

Time knob: Rotate the Time knob to the right, and the Timer stopwatch on the screen

Shenzhen SanQianJia Technology Co., Ltd.

will increase by the number of grids you rotate. Rotate the Time knob to the left, and the Timer stopwatch on the screen will decrease by the number of grids you rotate. Press the Time knob to the middle to confirm the new countdown time. You will hear a buzzer and the countdown timer behind the "T" in the lower corner of the screen will change to the time you set.

Power knob: Turn the Power knob to the right, and the percentage displayed after the "P" in the lower right corner of the screen will increase according to the number of grids you rotate. Turn the Power knob to the left, and the percentage displayed after the "P" in the lower right corner of the screen will decrease according to the number of grids you rotate. The irradiation energy of the UV LED irradiation head will also change in brightness due to your adjustment.

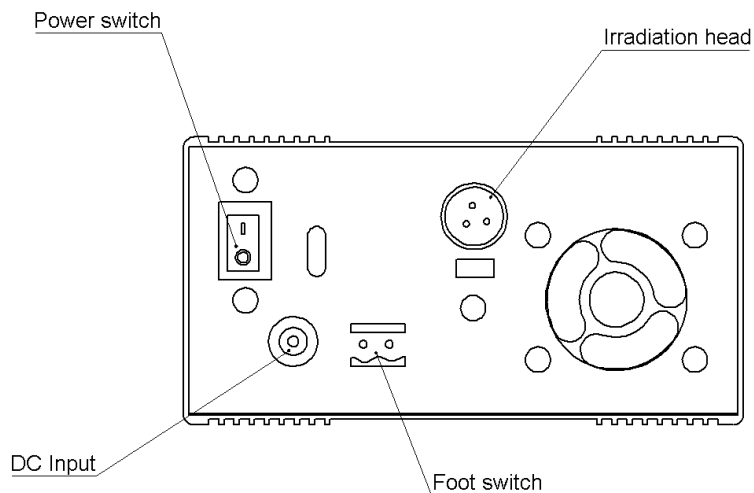

Power switch: Press the vertical line side of the boat switch to turn on the controller, and press the circle side of the boat switch to turn off the controller..

Shenzhen SanQianJia Technology Co., Ltd.

Foot switch: According to the positive and negative positions of the foot switch, enter the foot switch, press the foot switch to turn on the UV LED irradiation head, and press the foot switch again to turn off the UV LED irradiation head..

Irradiation head: For connecting UVLED irradiation head.

DC Input: For DC power supply with 12V 2A adapter.

Precautions:

The irradiation head should not be lit with high power for a long time to avoid burns!

Do not directly irradiate the skin with UV, so as not to cause damage to the skin!